

GW MKIII DELUGE VALVE - ALUBRONZE EXTERNAL RESET, PNEUMATIC

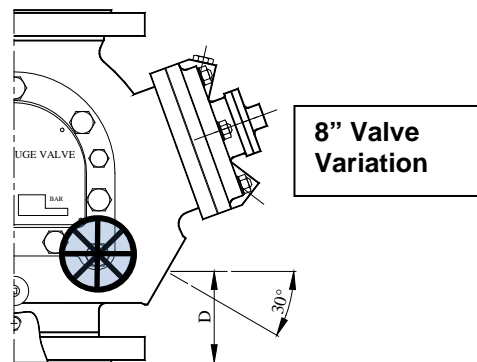

GW SPRINKLER A/S

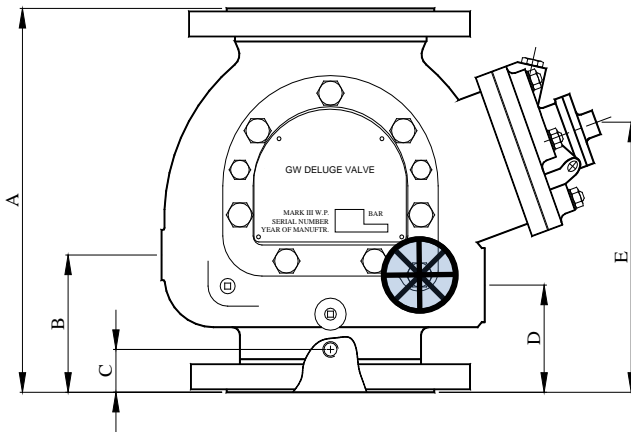
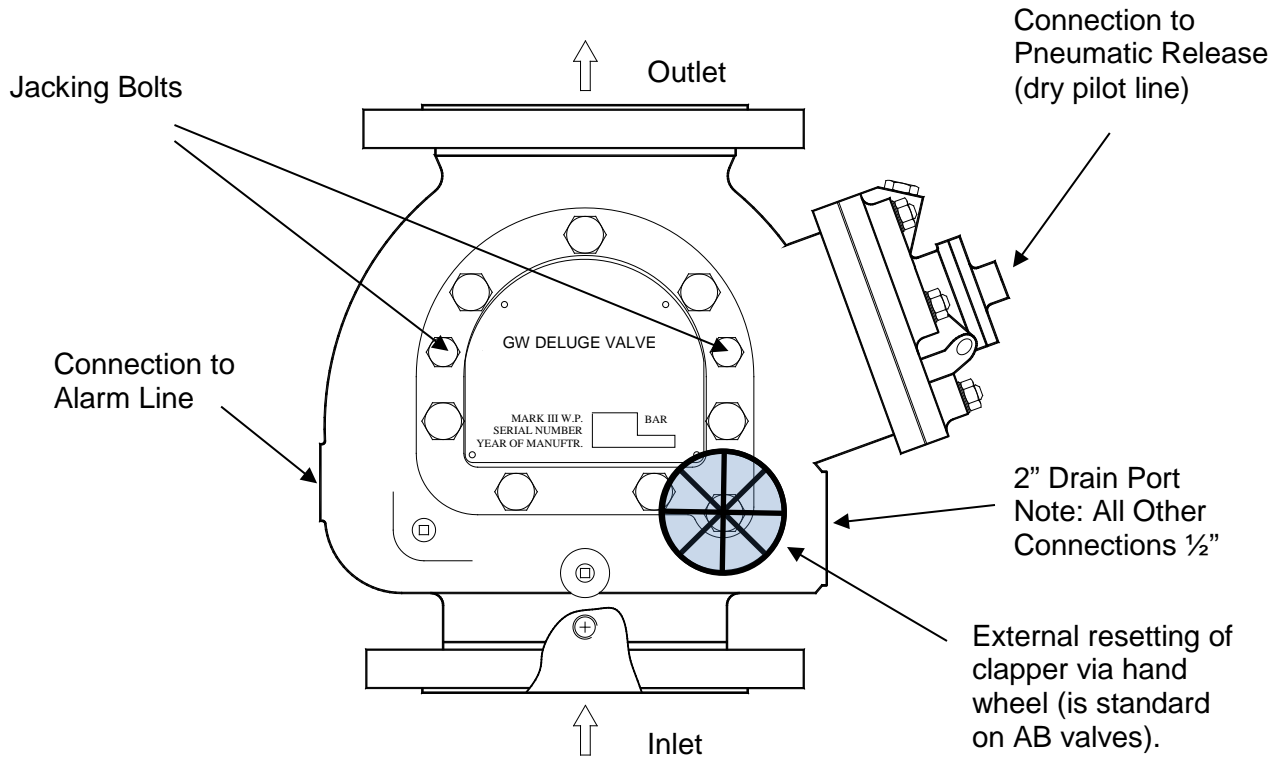

Size	100 mm	150mm	200mm
A	335	390	500
B	140	146	172
C	45	48	56
D	111	118	111
E	259	273	309

GW SPRINKLER A/S

Kastanievej 15, DK-5620 Glamsbjerg, Denmark

Tel: +45 64 72 20 55 Fax: +45 64 72 22 55

E-mail: sales.dep@gwsprinkler.com

Data sheet: GW MKIII Deluge Valve
AluBronze
Pneumatic

Page 1 of 6

Date: 01 December 2016

Data sheet no.: **GW DV010 1001 C**

GW MKIII DELUGE VALVE - ALUBRONZE EXTERNAL RESET, PNEUMATIC



GW SPRINKLER A/S

General Description

The GW MKIII deluge valve is a straight through, bottom entry / top exit, firewater latched deluge valve specifically designed and approved for automatic fire protection systems. The integrated actuator uses the fire main water pressure and the pneumatic pilot line pressure to keep the valve closed.

When the pilot line air pressure is reduced to below the trip point, the hydraulic pressure in the actuator (diaphragm chamber) is released – and the GW MKIII deluge valve rapidly opens to provide a virtually uninterrupted water passage with excellent water flow / pressure drop characteristics.

Method of Operation

Water under pressure from the valve inlet is fed via a non-return valve and a restricted orifice into the hydraulic chamber (1). This applies pressure on the diaphragm (2), which via the push rod (3) forces the spring loaded lever (4) to hold the clapper (5) in closed position. The resultant force due to the supply pressure acting on the push rod is multiplied by the mechanical advantage of the lever and is more than sufficient to hold the clapper closed against normal supply pressure surges.

The pneumatic diaphragm (6) retains the water pressure in the chamber by closing the water exit port/orifice (7). To trip the valve the pilot line air pressure is released by one of 3 methods:

1. Opening a manual release valve.
2. Operation of a solenoid valve (electrical).
3. Fracture of a pilot line detector head

Once the air pressure has been lost, water can escape from the hydraulic chamber faster than it can be replaced due to the restricted inlet orifice. The hydraulic pressure acting on the lever via the push rod is reduced to the point where it can no longer hold the lever in forward locking position. The lever is pushed back by the inlet water pressure acting on the clapper – allowing the clapper to move to the open position.

As the clapper moves open, the spring loaded lever moves forward as a latch preventing the clapper to fall back in the closed position. To re-set the clapper the external reset hand wheel (8+9) is turned clockwise

Water flows to the pipe work – and if required water can be diverted via the alarm port (10) to sound a mechanical or electrical alarm.

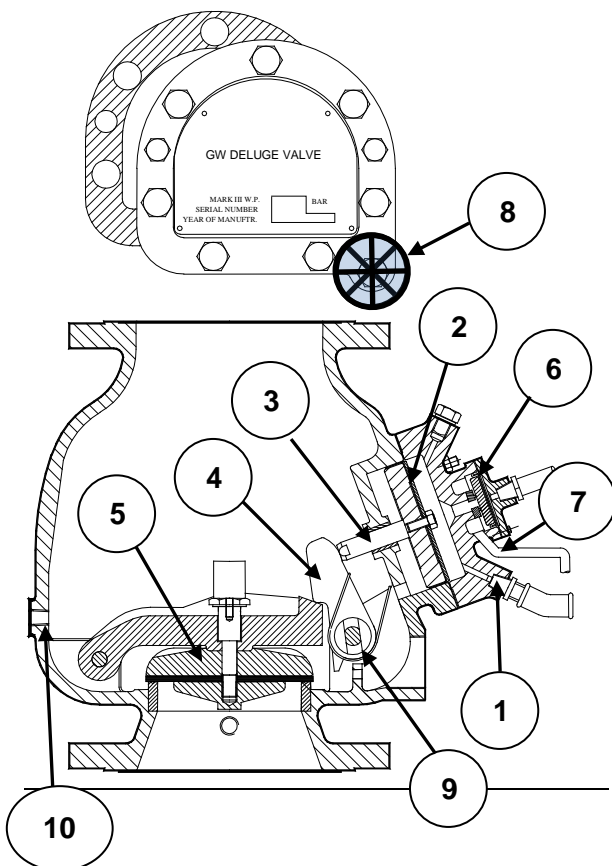

GW SPRINKLER A/S

Kastanievej 15, DK-5620 Glamsbjerg, Denmark

Tel: +45 64 72 20 55 Fax: +45 64 72 22 55

E-mail: sales.dep@gwsprinkler.com

Data sheet: GW MKIII Deluge Valve
AluBronze
Pneumatic

Page 2 of 6

Date: 01 December 2016

Data sheet no.: **GW DV010 1001 C**

GW MKIII DELUGE VALVE - ALUBRONZE EXTERNAL RESET, PNEUMATIC



GW SPRINKLER A/S

Application

The GW MKIII Deluge Valve is used to control the water supply to a deluge fire protection system, typically feeding a number of open water spray nozzles fitted in a fixed grid over the protected area. The deluge valve actively holds back the water in the stand by position – and upon instruction (manually or via a detection system) the deluge valve is tripped, and instantaneously supplies water through the downstream pipework to be evenly distributed over the hazard by the open nozzles.

Marine & Off Shore

The GW MKIII Deluge valve in nickel aluminium bronze (body) is manufactured using only corrosion resistant components, which makes it highly durable and applicable for service in harsh environments – e.g. oil & gas, petro chemical process industry, marine and off shore.

Flow vs. Pressure Loss

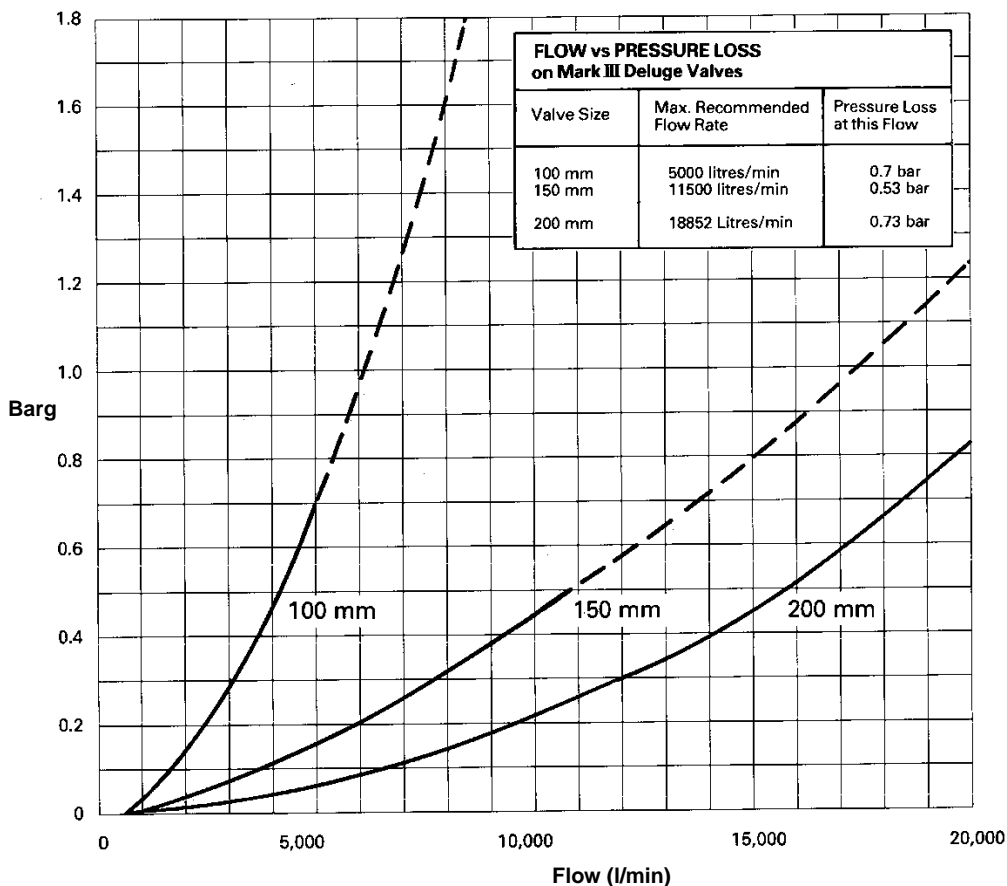

Pilot line air pressure vs. hydraulic inlet pressure

Valve sizes 100,150 & 200 mm	
Hydraulic pressure (valve inlet) bar	Pilot line air pressure (diaphragmchamber) bar
1	0,3
2	0,7
3	1,0
4	1,4
5	1,7
6	2,1
7	2,4
8	2,7
9	3,1
10	3,4
11	3,8
12	4,1
13	4,5
14	4,8
15	5,2
16	5,5
17	5,8
18	6,2
19	6,5
20	6,9

GW SPRINKLER A/S

Kastanievej 15, DK-5620 Glamsbjerg, Denmark
Tel: +45 64 72 20 55 Fax: +45 64 72 22 55
E-mail: sales.dep@gwsprinkler.com

Data sheet: GW MKIII Deluge Valve
AluBronze
Pneumatic

Data sheet no.: **GW DV010 1001 C**

Page 3 of 6

Date: 01 December 2016

GW MKIII DELUGE VALVE - ALUBRONZE EXTERNAL RESET, PNEUMATIC



GW SPRINKLER A/S

Technical data

	100 mm (4")	150mm (6")	200mm (8")
Weight (approx.)	56 kg	88 kg	178 kg
Max. recommended flow rate	5.000 l/min	11.500 l/min	18.852 l/min
Pressure loss at max. flow	0,7 bar	0,53 bar	0,73 bar
Factory test pressure (body)	35 bar	35 bar	35 bar
Max. working pressure (body)	20 bar	20 bar	20 bar
Installation	vertical	vertical	vertical
Flange dimension (inlet and outlet)	ANSI 16.5 - Class 150	ANSI 16.5 - Class 150	ANSI 16.5 - Class 150
Pneumatic pilot line air pressure	See page 3	See page 3	See page 3
Material			
Valve Body + internal parts	ASTM B148 C95800	ASTM B148 C95800	ASTM B148 C95800
Diaphragm Chamber	Gunmetal LG4	Gunmetal LG4	Gunmetal LG4
Trim pipe (deluge valve station)	SS316	SS316	SS316
Approval			
LPCB (basic valve)	Cert. no. 084a/01	Cert. no. 084a/01	Cert. no. 084a/01

Spare Parts

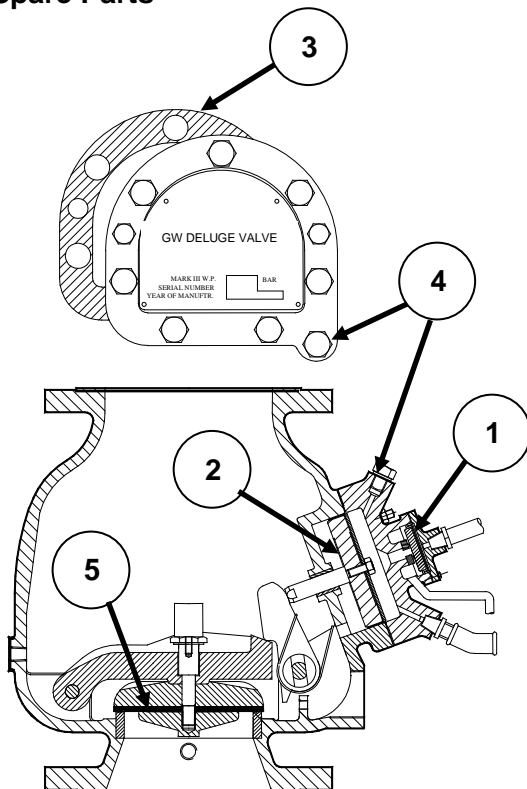

Pos.		100 mm	150 mm	200 mm
		Part Number		
1	Small Diaphragm and Piston Assembly (1)	BE24510	BE24510	BE24510
2	Push Rod Assembly (2)	ES24554	ES24555	ES24557
3	Cover Plate Gasket	BE2670	BE24560	BE24671
4	Dowty Washer	DE14229	DE14229	DE14229
5	Clapper Seal (rubber)	DE07607	DE07571	DE07628

- (1) The Small Diaphragm is only supplied with its associated plastic disc (piston) to avoid incorrect fitting. The two parts are bonded together and should not be separated.
- (2) The Push Rod Assembly is a sub-assembly consisting of a Large Diaphragm + Piston Disc + Push Rod. It is only supplied pre-assembled to avoid incorrect fitting of individual parts.

GW SPRINKLER A/S

Kastanievej 15, DK-5620 Glamsbjerg, Denmark
Tel: +45 64 72 20 55 Fax: +45 64 72 22 55
E-mail: sales.dep@gwsprinkler.com

Data sheet: GW MKIII Deluge Valve
AluBronze
Pneumatic

Page 4 of 6

Data sheet no.: **GW DV010 1001 C**

Date: 01 December 2016

GW MKIII DELUGE VALVE - ALUBRONZE EXTERNAL RESET, PNEUMATIC

Deluge Valve Station (trimmed)

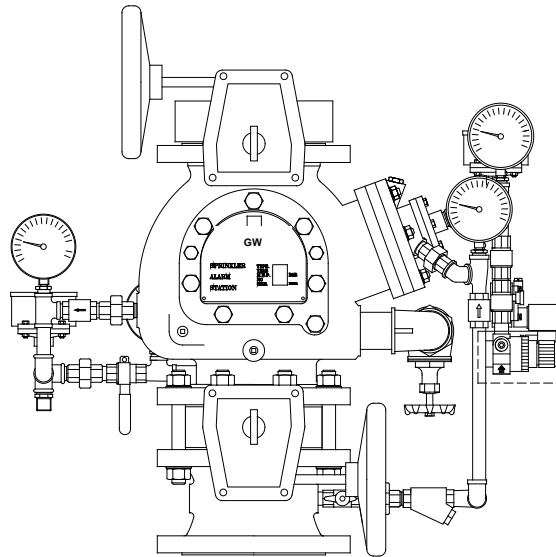

The GW MKIII Deluge Valve is available in the fully trimmed version (Deluge Valve Station) – ready to install and connect in the system pipe work.

General Description

The GW MKIII Deluge Valve Station comprises a GW MKIII Deluge Valve (LPC approved) sandwiched between butterfly isolation valves (to LPC rules), a spool piece (aluminium bronze) normally flanged ANSI B16.5 and all necessary trim (SS316 pipe), common key padlocks, pressure gauges and pressure switches to enable the valve to operate.

All stations are arranged for bottom entry, top exit, flanged for supply pressures up to 20 bar.

Stations are supplied in three sizes, 100, 150 and 200mm nominal bore, and are supplied pressure tested with all trim fully assembled, crated for shipment.

Standard trim:

Butterfly isolation valves top and bottom (lower valve located with a spool piece).

Water priming line to feed the large hydraulic diaphragm complete with strainer, lockable isolation valve, pressure gauge and non-return valve.

Bell line with lockable isolation valve, bell test line complete with lockable ball valve, drip union, pressure switch factory set to operate at 1 bar rising and a non-return valve to stop water entering the valve body during the bell test, pressure gauge.

Drain valve, 2" globe. Pneumatic line with pressure gauge, manual release via a lockable ball valve and facility for pneumatic detector line connection.

GW SPRINKLER A/S

Kastanievej 15, DK-5620 Glamsbjerg, Denmark
Tel: +45 64 72 20 55 Fax: +45 64 72 22 55
E-mail: sales.dep@gwsprinkler.com

Data sheet: GW MKIII Deluge Valve
AluBronze
Pneumatic

Page 5 of 6

Date: 01 December 2016

Data sheet no.: **GW DV010 1001 C**

GW MKIII DELUGE VALVE - ALUBRONZE EXTERNAL RESET, PNEUMATIC



GW SPRINKLER A/S

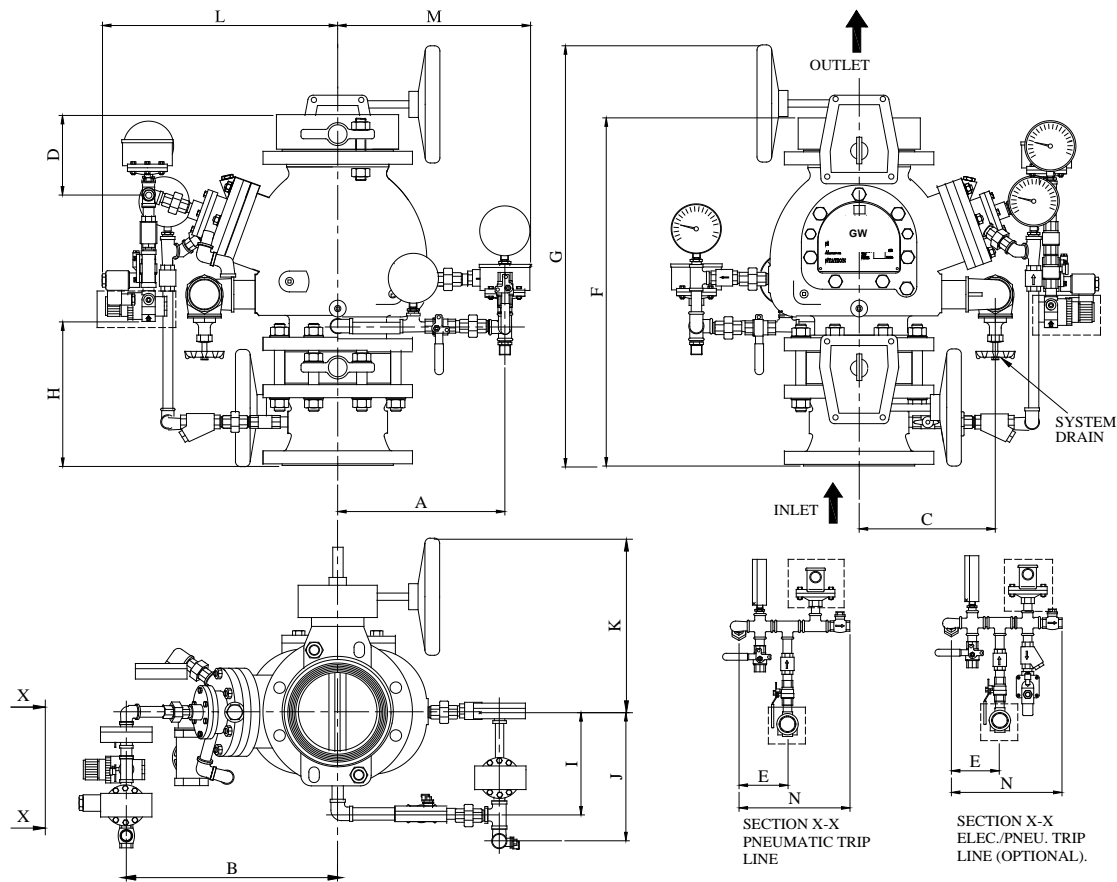

Size mm	A	B	C	D	E	F	G	H	I	J	K	L	M	N	Weight approx.
100	325	380	270	55	130	600	710	265	145	180	240	440	370	300	162 kg
150	325	400	320	100	130	660	820	280	185	240	320	440	370	300	203 kg
200	375	440	365	175	130	750	910	295	215	270	349	480	420	300	302 kg

The dimensions can vary due to component and assembly tolerances.

Optional extras:

- Water motor alarm gong (supplied separate)
- Glycerine filled pressure gauges.
- Single or double solenoid valves for releasing latching air pressure (Electro/Pneumatic operation)
- Monitored (with micro switch) butterfly valves and explosion proof pressure switches and solenoid valves.

GW SPRINKLER A/S

Kastanievej 15, DK-5620 Glamsbjerg, Denmark
Tel: +45 64 72 20 55 Fax: +45 64 72 22 55
E-mail: sales.dep@gwsprinkler.com

Data sheet: GW MKIII Deluge Valve
AluBronze
Pneumatic

Page 6 of 6

Data sheet no.: **GW DV010 1001 C**

Date: 01 December 2016